

Monorail trolley, reduced headroom - Reeving 4/1

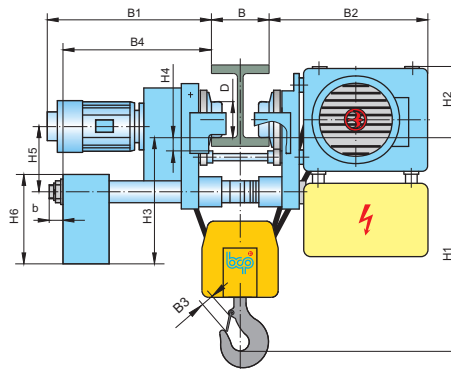
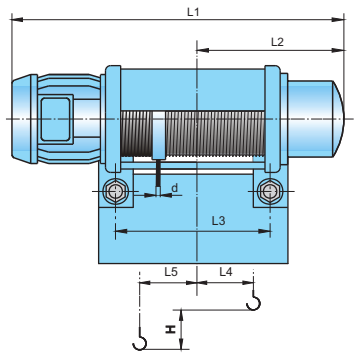

Type	Lifting height, H, m	Size of drums, table 1	Capacity, kg	General dimensions, mm																					
				L1				L2	L3	L4	L5	B	B1	B2	B3	B4	H1	H2	H3	H4	H5	H6	D	b	d
				V1	V1/M1	V2	V2/M2																		
MH 3-05	6,5	03	2000	925	965	925	965	420	429	45,5	41	100 ... 170	500	460	40	510	615	164	440	35	233	310	100	27	7
	10	04		1125	1165	1125	1165	520	629	146	-9	171 ... 240													
	13,5	05		1325	1365	1325	1365	620	829	246	-59	241 ... 300													
MH 3-08	6,5	03	3200	925	965	925	965	420	429	45,5	41	100 ... 170	500	470	45	490	625	164	440	35	233	310	100	27	7
	10	04		1125	1165	1125	1165	520	629	146	-9	171 ... 240													
	13,5	05		1325	1365	1325	1365	620	829	246	-59	241 ... 300													
MHM 4-10	6	03	4000	1025	1095	1025	1095	470	441	29	54	100 ... 170	515	511	50	485	660	204	447	35,5	240	310	125	27	10
	9	04		1225	1295	1225	1295	570	641	129	4	171 ... 240													
	12,5	05		1425	1495	1425	1495	670	841	229	-46	241 ... 300													
MHM 5-16	5,5	03	6300	1090	1175	1120	1175	495	491	25	67	100 ... 170	525	527	56	490	700	198	465	38	255	310	160	32	12 (10)
	8,5	04		1310	1395	1340	1395	605	711	135	12	171 ... 240													
	11,5	05		1530	1615	1560	1615	715	931	245	-42	241 ... 300													
	14,5	06		1750	1835	1780	1835	825	1151	355	-97														
MH 6-25	5	03	10000	1120	1210	1155	1210	505	453	-34	112	100 ... 170	550	626	71	495	830	225	495	60	286	310	200	35	15 (13)
	8	04		1330	1420	1365	1420	610	663	71	60	171 ... 240													
	11	05		1540	1630	1575	1630	715	873	176	7	241 ... 300													
	12,5	06		1645	1735	1680	1735	770	978	228	-19														
15	07	1820	1910	1855	1910	860	1153	315	-62																
MH 7-40	8	04	16000	1460	1495	-	-	675	713	38	100	100 ... 170	575	766	71	730	960	303	525	68	308	310	250	35	18 (15)
	11	05		1675	1710	-	-	785	928	128	62	171 ... 240													
	14	06		1890	1925	-	-	890	1143	236	8	241 ... 300													
	17	07		2100	2135	-	-	995	1353	341	-44														